PICKLEBALL UNIVERSITY

A Curriculum for Majoring in
the Fastest Growing Sport



1ST EDITION

ABOUT US

We are an organization dedicated to spreading the growth of pickleball, welcoming newcomers with easy ways to learn the game and offering strategies and tips for pickleball pros. We launched PickleballUniversity.com in 2021 and have amassed a pickleball community from all over the world. You can learn more about us or subscribe to our newsletter at PickleballUniversity.com.

PICKLEBALL UNIVERSITY

**A Curriculum for Majoring in
the Fastest Growing Sport**



Copyright 2021 by Pickleball University. Printed and bound in USA. All rights reserved.
No part of this book may be reproduced in any form or by any electronic or mechanical
means including information storage, and retrieval systems without permission in writing
from the publisher, except by a reviewer, who may quote brief passages in a review.
First edition.

SYLLABUS

	ORIENTATION	07
1	FRESHMAN	13
	PADDLES	14
	PICKLEBALLS	15
	OTHER APPAREL	17
	THE COURT	18
	THE RULES	20
2	SOPHOMORE	27
	DINKING	28
	THIRD SHOTS	32
	PROCESS TO LEARNING NEW SHOTS	35
3	JUNIOR	41
	ADVANCED SHOT TYPES	42
	PLAY TO YOUR OPPONENT'S WEAKNESS	44
	PARTNER PLAY	46
4	SENIOR	53
	PICKLEBALL TOURNAMENT	54
	BECOMING A PRO	60
	GLOSSARY	65

WELCOME TO

PICKLEBALL  UNIVERSITY

ORIENTATION

We know starting any form of school can be intimidating (uhh, where do all the cool kids sit at lunch?). So before you begin, we wanted to offer an orientation to ease your nerves.

First thing's first, pickleball is for all. Say it with us.

**PICKLEBALL.
IS.
FOR.
ALL.**

It's why it's the fastest growing sport in America. And why we all started playing in the first place. Here's what we always say. You start playing pickleball because of its welcoming community. You keep playing pickleball because of its fun, competitive play.

So welcome! Welcome to the most welcoming University you'll ever experience.

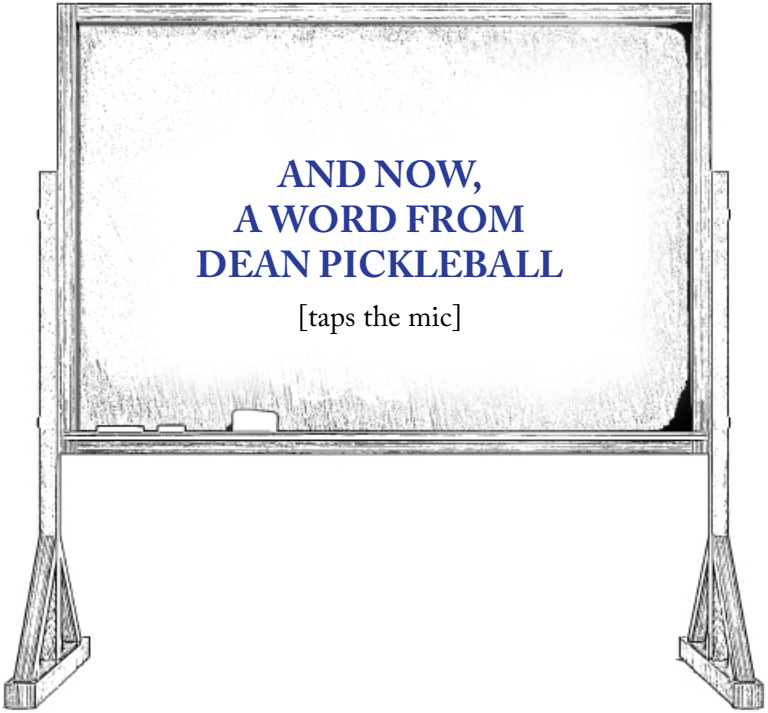

“Ehhhhmmm! Hello, and welcome, all my fellow pickleballers, to the Pickleball University orientation. In 1965, a gentleman by the name of Joel Pritchard sought to solve one of our nation’s greatest challenges: How to keep his bored children entertained at home during the summer. What began as a badminton mission, ended up as two table tennis paddles and a plastic ball. Eventually, they lowered the net and created the rules for ... Pickleball. Which was either named after the family dog, Pickles. Or the fact that the combination of sports reminded Joan, Joel’s wife, of the pickle boat in a crew where oarsmen were chosen from the leftovers of other boats. No one knows which origin story is true.

Since then, pickleball has become one of the fastest growing sports in the world.

And we’re so happy to contribute to its growth by launching the first ever Pickleball University.

My fellow picklers, you’re about to take the first step on a journey that’s sure to be enjoyable.

Thank you.”

WHAT TO EXPECT

We're called Pickleball University for a reason. This book is broken out into sections you're probably already expecting.

FRESHMAN.
SOPHOMORE.
JUNIOR.
SENIOR.

And in the back of the book, we've included a glossary of frequently used pickleball terms. So feel free to flip forward any time to brush up on your on-court vernacular.

The curriculum aims to help any and every pickler. So whether you're a beginner, starting your freshman year with wide eyes or a transfer student coming in on your junior year, you'll find tips and tricks and strategies for every level.

And believe us when we say, our graduation rate is off the charts. You're in good hands here at PBU and we can already tell you're going to thrive here.

IT'S TIME TO GET STARTED!





CHAPTER 1

FRESHMAN

Okay. Okay. Okay. Have a seat, everyone. Pickleball 101 is in session. But this isn't your average 101 course. Because pickleball isn't your average topic. We won't bore you with a syllabus on your first day. We're just going to dive right in.

**Let's start with the gear.
Because you can't play pickleball without
paddles and pickleballs.**

PADDLES



Pickleball paddles are used to hit the pickleball. They're like larger ping pong paddles with a tennis racket grip. They range in sizes, weights, colors, materials, etc. But most modern paddles are made from a composite material and weigh 7 to 8 ounces. Though, you will still find plenty of heavier wood paddles out there, too.

Our advice for beginners? Try a fiberglass- or graphite-made paddle first. These paddles should feel comfortable in your hand. And should be light enough to play for hours without killing your arm. Yet powerful enough to give you the oomph you need to get the ball over the net.

To grip the paddle, extend your hand as if you're about to shake someone's hand. Your thumb and pointer finger make a sort of "V." See that? That's where you put the paddle and wrap your fingers around it. In terms of tightness, on a scale of 1-10 (1 being dropping the paddle; 10 being death grip), you should grip it at a 6-7 in general.

Every pickleball paddle has a sweet spot. Meaning, a spot (usually in the center of the paddle) where you want to strike the ball for the best chance of being accurate and powerful. There's no way we can describe what that feels like here in this book. So you're just going to have to get out there and play to find out for yourself.

EXTRA CREDIT

It is believed that the first composite pickleball paddle was made from airplane scrap material.

PICKLEBALLS

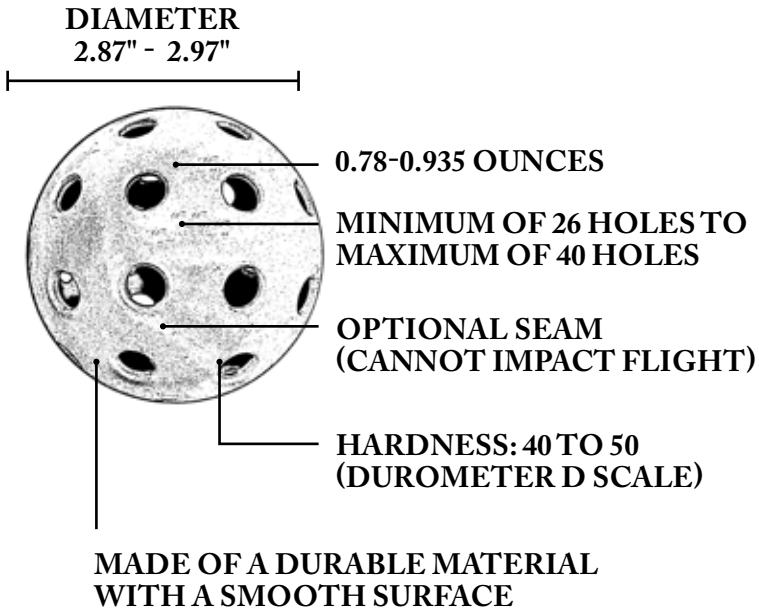

We won't over complicate this. A pickleball is a pickleball. Especially when you're just starting out. They are basically heavier, more durable wiffle balls. Usually yellow or green. Don't worry about finding the perfect pickleball just yet. Simply note if you're purchasing or playing with an indoor pickleball or an outdoor pickleball.

First off, no one is going to arrest you for playing with an indoor pickleball outside. Or vice versa. However, there are some differences. And we're here to learn. Right?

First indoor pickleballs. You'll notice the holes are a little larger than an outdoor ball and there are fewer holes all together. If you examine them closely, you'll also notice indoor balls are softer, lighter, and a little less bouncy. Meaning you have a bit more control and can play around with more powerful shots. If you're in a really heated match, you'll enjoy the fact that they also hurt less when you find yourself in front of a slam.

Outdoor pickleballs are generally the reverse. Smaller holes and more of them. A little harder, heavier, and bouncier. They crack when they get worn out. Whereas indoor balls just get too soft. You're going to want to watch your control with outdoor balls. They're going to pop off the paddle a lot harder than an indoor ball. And watch out if a hot shot is coming at you!



OTHER APPAREL

We've covered paddles. We've covered pickleballs. All you need is a net and you're on your way! We'll get to the court soon. But first, we wanted to mention apparel.

You can absolutely find pickleball-specific clothes, shoes, headbands, accessories, everything. And if you're all-in on pickleball (woop woop!), go for it.

But if you don't want to update your closet with pickleball goods, not to worry. Tennis apparel works, general athletic gear works, athleisure works, heck throw on some jeans and play casually. Whatever you want to do.

If you're like us and appreciate a dress code on a wedding invite, here's what we'd say about pickleball fashion. Think tennis. Or golf. Think activewear in general. And you're good.

YES	NO
	

THE COURT

The court is split up into several parts.

First, the net divides the court in half. Like tennis. Or ping pong. Opponents play on opposite sides of the net. In doubles, your partner is on the same side of the net as you. And the opposing duo remains on the opposite side.

Then, there's the line that runs parallel to the net, 7 feet away from the net, on both sides of the court. This line is called the Kitchen Line. And the space between the Kitchen Line and the net is called the Kitchen. Or No-Volley Zone. More on that to come.

From the Kitchen Line, a line perpendicular to the net runs to the baseline of the court. This line is called the Center Line. And it divides service areas on the court. More on that to come.

You'll find courts of all kinds in all sorts of locations. Chalk outline in a driveway. Taped-off tennis courts. And of course, official pickleball courts. They're popping up all around the world these days. And if you're in search of a court near you, we recommend going online and searching for pickleball in your area. You're sure to find a place to play and once you do, you'll be plugged in to your local pickleball community.

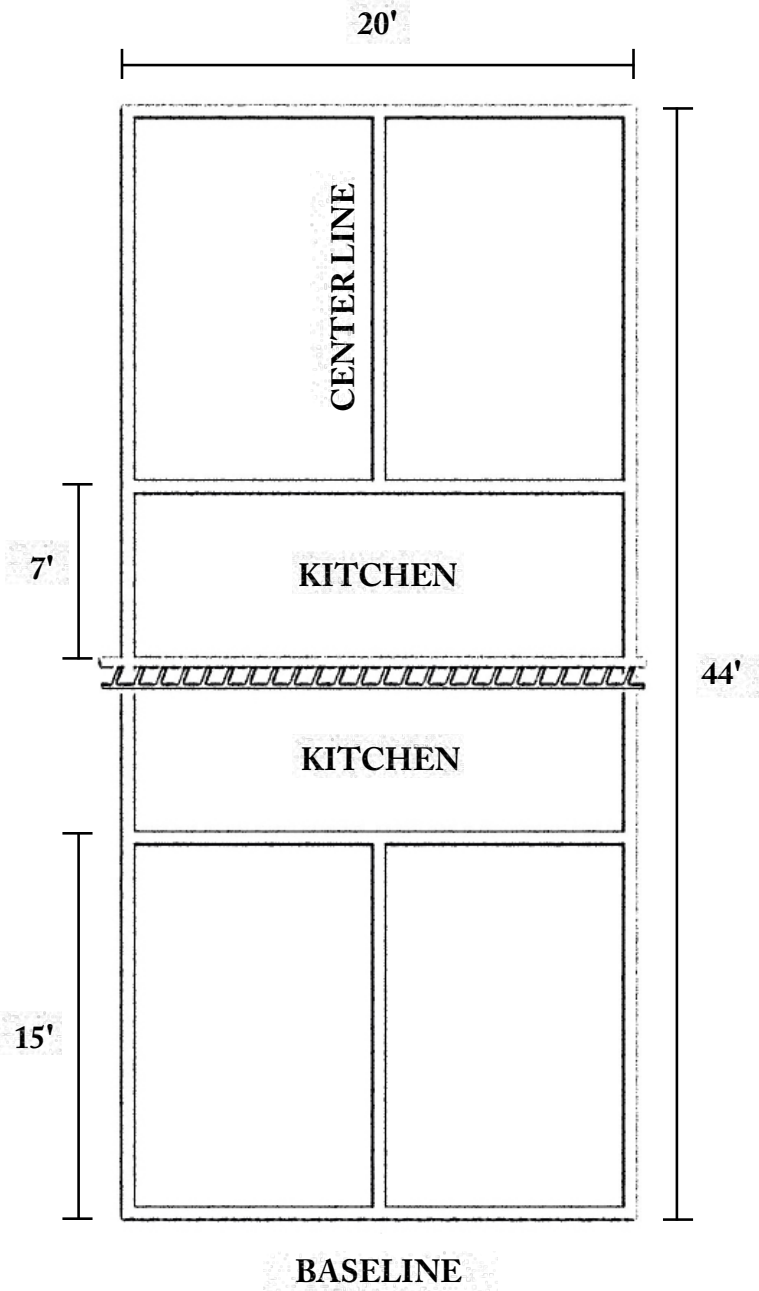

THE RULES

You're almost done with your freshman year at Pickleball University. Can you believe it? By now, you know the gear needed to play. You know what the court looks like and how it's divided. Next up, the rules.



SERVING

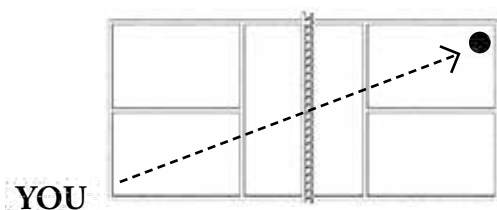

You serve from behind the baseline. To start, you'll serve on the right side of the Center Line. But then you alternate between right and left each time you serve. Unlike ping pong, pickleball is played one serve at a time. Meaning, if you're serving and you win the point, you keep serving. If you're serving and you lose the point, the opponent serves next. And so on.

Say it's your serve. And you're serving from the right side of the baseline. The ball must land in the left service area on your opponent's side. Meaning, the ball must go over the net and across the court diagonally.

When serving, you must hit the ball below your waist. We'll talk about different serving techniques in your sophomore year, but for now, hold the ball in your non-dominant hand at a height that's about half-way up your thigh. Then, with your dominant/paddle hand, swing to hit the ball out of your hand, releasing the ball from your hand right before the paddle strikes it.

It's going to take some practice to get your serve to land in the desired service area. So to start, grab some pickleballs and continue to serve until you get a feel for how hard and how high to hit the ball.

THE 2-SHOT RULE

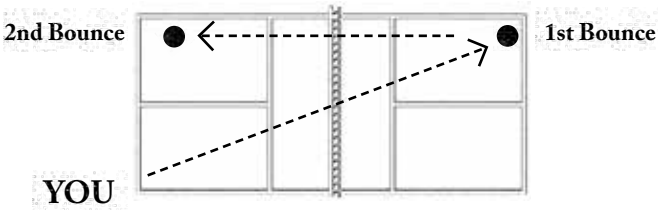

You just hit a serve that lands in the desired service area on your opponent's side. Congrats! Now what?

The 2-shot rule states that the first two shots in a pickleball point have to be played on the bounce. Meaning the ball must bounce before you can hit it.

So again, your serve lands in. It bounces. Your opponent returns the serve (which can land anywhere on your side of the net). Then, you must let the return bounce before hitting it back.

Once the first two shots have been played, you can volley the ball. Meaning, you can hit the ball without it bouncing first.

Except in the Kitchen.

THE KITCHEN

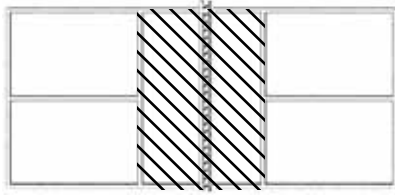

No-Volley Zone

Remember the Kitchen Line? This is what makes pickleball so unique. You cannot hit the ball out of the air if your foot is over the Kitchen Line. This is why you'll see many players standing right at the Kitchen Line. It is also referred to as the No-Volley Line or No-Volley Zone for this reason.

EXTRA CREDIT

It's illegal to hit a volley shot in the Non-Volley Zone, and when it does happen, it's called a "Volley Llama." Even the Dean doesn't know the origin of that phrase, but we don't care because it's fun to say.



SCORING

You earn points by your opponent making errors. If the ball lands outside of the sidelines or baseline, you earn a point. If the ball goes into the net, you earn a point. If the ball bounces twice on your opponent's side, you earn a point. If your opponent violates the 2-shot Rule, you earn a point. And if your opponent volleys a shot in the Kitchen, you earn a point.

Now, you must be serving to earn a point. If you are serving, and you make an error, the serve goes to your opponent. But there is no change in the score.

Games are usually played to 11 points and you must win by 2. However, some games will be played to 15 or 21. Just make sure it's agreed upon by both sides before starting the game.

DOUBLES

You may also play doubles in pickleball. It's a great way to get more people involved. And the rules are essentially the same. Except you will alternate serves with your partner after a sideout. Meaning, you'll serve until you or your partner makes an error, alternating sides each point. Then, your opponents will do the same. When the opposing serving team makes an error, the serve will come back to your partner.

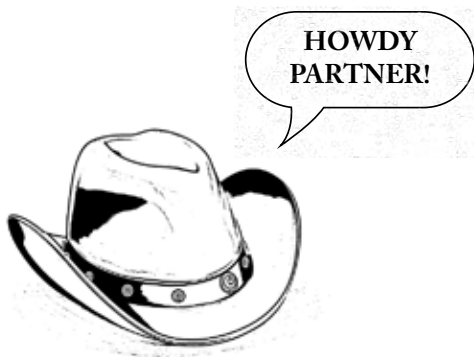



**PUT DOWN THE BOOK.
WE REPEAT. PUT DOWN THE BOOK.**

Congratulations on making it through your freshman year! You're ready to get out on the court and put your new-found knowledge to use!

Think of it as an internship. You learned the rules. Now, put them in practice. Once you've played enough to feel comfortable with the overall flow of the game, come on back for your sophomore course.

And remember, you're an intern out there. You're not going to play perfectly. The goal is to learn and network with other pickleballers.

Class dismissed!



CHAPTER 2

SOPHOMORE

Welcome to your sophomore year at Pickleball University. We hope your summer was full of pickleball play! By now, you should understand the rules of the game, feel confident serving, and be able to rally fairly well.

Pickleball isn't one of those majors where you can forget what happened freshman year and move on to your sophomore year. Sorry. It's a major that builds on itself.

**So, what are we building this year? In a word: shots.
No. Not the shots you were doing in your actual freshman year. Types of pickleball shots that will elevate your game from beginner to intermediate.**

DINKING

Let's start with the definition, as it pertains to pickleball.



DINK

/diNGk/

A brilliantly controlled shot that lands in your opponent's Kitchen.

Dinking is what differentiates pickleball from all other racket sports. It's as much a skill as it is a strategy.

Dinking happens at the Kitchen Line. Often when both sides are at their respective Kitchen Lines.

Since you cannot volley the pickleball in the Kitchen, a great technique is to softly lob the ball over the net and get it to land in your opponent's Kitchen. Think about it. If the ball softly lands in their Kitchen, your opponent simply cannot spike the return. It's science. They will have to lob a return back over the net, giving you the power to control how the point plays out.

That's dinking. And you'll see it in all levels of play, especially in higher-level tournaments.

A green ribbon banner with a white border, containing the text "EXTRA CREDIT" in white, bold, uppercase letters.

EXTRA CREDIT

**Please always remember to dink responsibly.
And never get behind the wheel when dinking.**

Here are Pickleball University's five tips to get you dinking like an experienced player.

1. DINK WITH A PURPOSE

When you hit a dink, think about your goal. Are you trying to hit the shot into the Kitchen so your opponent can't spike it back at you? That's a great start, but you'll also want your dink to move your opponent out of position. You want to start aiming your dinks in areas that are harder to reach and force your opponent to make a tough shot, letting you put away the point.

EXTRA CREDIT

A good rule of thumb is to dink the ball toward where your opponent isn't.

2. SWITCH UP YOUR DINK

You can spend the whole game dinking back and forth between the same two players and basically hit a stalemate waiting for someone to slip up. After a while, try changing up your shot to catch your opponent off guard and out of position. If you're hitting a lot of dinks back and forth, try a cross-court dink to catch the opponent off guard and possibly out of position. Switching up your shot every once in a while can be a great way to get a leg up on the competition (and be ready for the person on the other side of the net to do the same).

3. STEP TO THE BALL

When you go to make your shot, having your feet in the right position makes a world of difference. Stepping toward the ball and setting your feet will give you more control and improve your dinking. If you know the dink is going to land into the Kitchen, you can step in the Kitchen before it lands to get into a position to return the ball. Just make sure you step right back out so you don't become a target.

4. UTILIZE THE CROSS-COURT DINK

The cross-court dink is a great way to get your opponent out of his/her comfort zone. A cross-court dink occurs when you hit a dink from one side of the court to the opposite side, like a serve but in the No-Volley Zone. The goal of a cross-court dink is to force your opponent to move by hitting the ball toward the far end of the court. With good placement, the other player will have to move off the court to even have a chance to return it, opening them up to an attack.

5. WHEN SHOULD YOU ATTACK THE BALL?

Sure, dinking is effective and necessary, but you can't dink forever. Eventually, you'll need to attack the ball to win the point. To do this, you'll either need to be aggressive or wait for your opponent to make a mistake. If the ball ever comes back above your waist, you should definitely attack it.

THIRD SHOT

Pop quiz! What's a third shot?

Correct! It is quite simply the third shot in every point rally.
The serve. The return. The third shot.

There are two types of Third Shots to consider.

First, the Third Shot Drop.

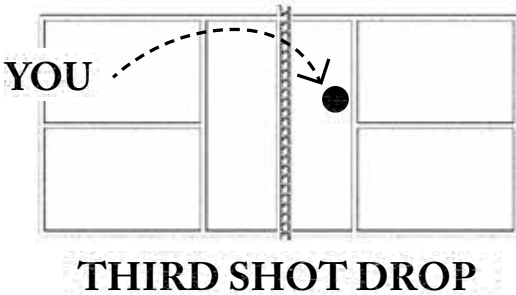

VS

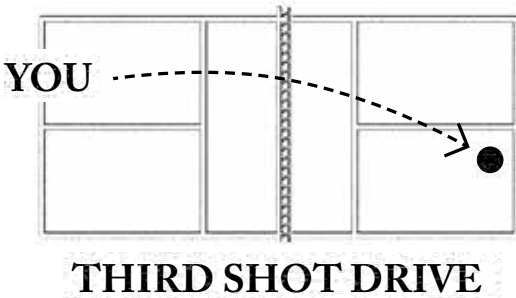

WHAT IS IT?

The third shot drop is essentially just what it sounds like; it's a drop shot that comes after the serve and return serve, hence the name "third shot drop." This particular shot is intended to arch upward and then drop into your opponent's Kitchen, effectively bringing play closer to the net and evening the chances of winning the rally.

WHAT'S THE BIG DEAL?

The third shot drop is an important play for the serving team. After the serve and return serve, the serving team is typically still back at the baseline away from the net while the opposing team has had the opportunity to inch closer to the net. This third shot drop is a slow, arching shot that, if done correctly, buys the serving team enough time to meet their opponents near the net. The dropping effect also makes it more difficult for your opponents to smash the ball down in the Kitchen, a move that could result in your team losing the rally. By moving your team closer to the net and lowering the level of play, you put yourself back in position to control the rally.

HOW IS IT DONE?

The third shot drop can take a lot of time and practice to master, but it will be worth your while. It might be helpful to think of it as a "long dink." Be sure you're consistent with your dink before you take on the challenge of the third shot drop. As you begin to feel more comfortable with your close-range dink, start moving back a few steps. Eventually, you'll find yourself at the baseline of the court and you'll see that your dink just needs more power and follow-through. Get low to the ground and stay there all the way through the shot; don't come back up too early to rush up to the Kitchen and ruin your shot in the process.

Next, the Third Shot Drive.

WHAT IS IT?

A driving shot that ideally lands deep in the opponent's service area. As opposed to the lofty nature of the Third Shot Drop, the Third Shot Drive is hit harder with the intention that the flight projection is flatter. In baseball terms, a line drive.

WHAT'S THE BIG DEAL?

When done correctly, the goal is to receive a more favorable fifth ball that allows you to approach the Kitchen safely. Basically, you're trying to pin your opponent close to their baseline, so they can't get to the Kitchen before you.

HOW IS IT DONE?

Practice makes perfect here. You're looking for a ball that's waist-torso-high that you can sweep your paddle through. You want to keep it as close to the net (in terms of height) as possible so your opponent will not be able to spike the ball back. The closer you can keep your shot to the net, the harder you'll be able to hit it.

SO WHEN DO I HIT A DROP VS. A DRIVE?

Good question. Part of it depends on the strengths and weaknesses of your opponent. For instance, if they struggle at the baseline, you may want to incorporate more Drives into your Third Shots. If they aren't strong at dinking, you should opt for the Third Shot Drop.

You should also play to your strengths. So if you're confident hitting a drive, go for it. Trust your instincts when the ball is returned to you. If the return sets you up to loft the ball back, try a Third Shot Drop. As with anything, keep practicing and be intentional about your Third Shots.

PROCESS TO LEARNING NEW SHOTS



STEP 1:
Conquer the dink.



STEP 2:
Get your Third Shots in order.

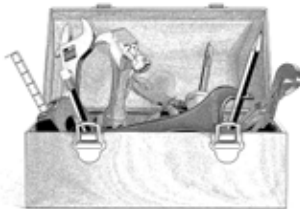

STEP 3:
Start putting more tools in your toolbox.

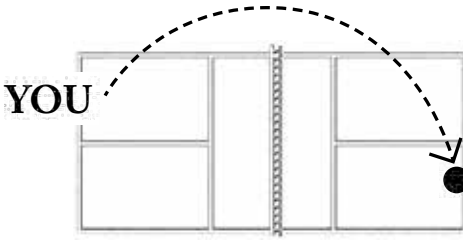

THE LOB

This might be the most underutilized shot in pickleball. For good reason. It's fairly difficult to 1) master this type of shot; And 2) find the perfect opening in a rally to use it.

The lob is a heavily arched shot that lands as close to your opponent's baseline as possible.

Here's the scenario. Both you and your opponent are at the Kitchen Line, dinking back and forth for several shots. Instead of dinking another one back, you lob the ball well over your opponent's head, so they have to race back and try to return it.

This does two things.

- 1) It creates a difficult return for your opponent. They'll have to turn their back to the net to chase after the ball, making it hard to then turn back around to hit the back over the net. Essentially, they have to be quicker than the ball.
- 2) It gets your opponent off the Kitchen Line, giving you the upper hand, as you'll still be at the Kitchen Line ready to return the ball if your opponent does get to it in time.

This shot, more than any other shot, is one that takes a lot of practice. It's hard to judge how high and how far you'll need to hit it, so you just need to do it over and over again to get used to how to hit it. No shortcuts here. Sorry.

THE OVERHEAD SMASH

Raise your arm over your head.
Now, drop your hand as if you have a flyswatter and you're going after one buzzing right in front of you.

That's an overhead smash.

This shot is less about finesse or skill.
And much more about capitalizing on any opportunity your opponent gives you to use it.

Say, for example, your opponent tries to lob the ball over you. But they don't get the ball high enough. You have the perfect opportunity to smash the ball back to them.

The key here is to aim for your opponent's feet. You want the ball going so fast that it's nearly impossible to return. And if it's heading for their feet, they likely won't have time to adjust their position for a return.

This is obviously a power shot. And with great power, comes great responsibility. So use it wisely out there.

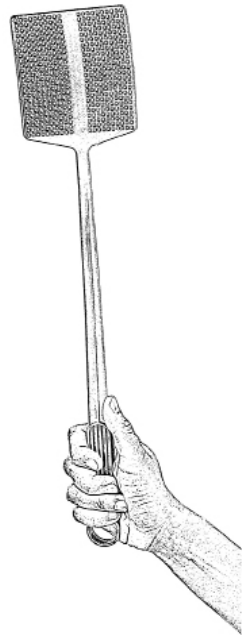

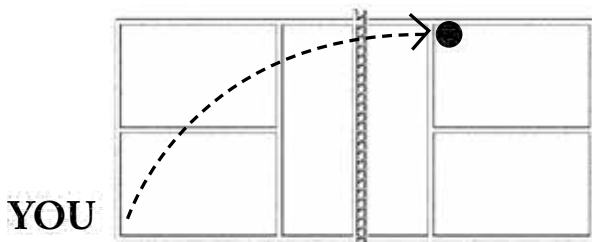

KITCHEN CORNER SERVE

If you're looking to switch up your serve, whether to surprise your opponent or improve your own skills, a Kitchen corner serve is a great choice. To execute this move, serve from the corner of your baseline and hit to the opposite corner of your opponent's Kitchen. This pushes them far out to the side, which will hopefully lead to a poor return that you can hit back. Keep in mind that you might want to hit softer on this serve than you normally would because it's a shorter shot.

EXTRA CREDIT

Mixing up your serve types is one of the best ways to keep your opponents on their toes. Master 3-4 serves you're always confident hitting, and use serves like this during key points in the game.



We covered a lot, sophomores! From dinking and third shots to mixing up your serves and incorporating other unique shot types.

We'll leave you with this.

Don't drive nails with a screwdriver. Use a hammer for nails. What we mean is this. Adding more shots and skills to your pickleball repertoire is like adding tools to your toolbox. Which is fantastic. But the real power comes in knowing which to use for certain situations.

Keep that in mind as you once again put down this book and get out there and play.

Class dismissed!



CHAPTER 3

JUNIOR

You're officially an upperclassman now! How does it feel?

We're guessing you've gained some confidence on the court.

You're probably playing with a diverse group of talent levels.

You might even be teaching some newbs out there.

Look at you.

We're proud of you.

You might even be thinking to yourself, "I'm a champion-level dinker, I incorporate several different shot types throughout a game, my serves are always in, where could I possibly go from here?"

Funny you should ask.

Where you're going is exactly where we're about to take you.

Buckle up!

ADVANCED SHOT TYPES

Remember the toolbox analogy from sophomore year? Where adding different kinds of pickleball shots is like adding tools to your toolbox? Same drill here to start your junior year. Let's add spin to your shots. You may notice that on the surface of your paddle, there is some texture. If not, don't freak out. These shots will still work. But the "grip" that is often applied to paddle surfaces allows you add another dimension to your play: spin.

CHIP (FOREHAND ROLL)

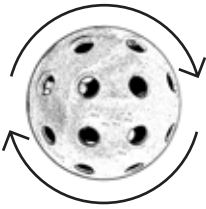

This shot takes advantage of the "shoulder high, let it fly" rule that most players follow. Hit down the Center Line, a chip or forehand roll is accomplished by pushing your wrist forward and rolling it through as you hit the ball upward. This puts a topspin on the ball that causes it to appear shoulder-high but dropping at the last minute to remain in play, effectively tricking your opponent into letting a good shot go.

BACKHAND ROLL

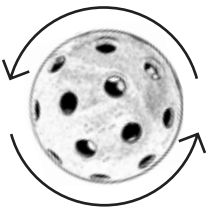

The backhand roll is taken from a shot in the Kitchen that comes in at about net height. It's best used when the ball isn't high enough to swat down onto your opponent's side of the court. Similar to the chip or forehand roll, this shot is hit from a low, squatted position with the goal of hitting the ball upward, but with a backhand swing as opposed to forehand. The key to success here is to really go for it without hesitation!

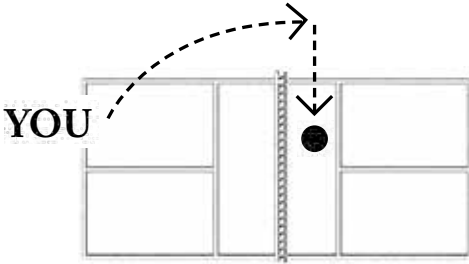

HYBRID LOB WITH TOPSPIN SERVE

The hybrid lob with topspin is a very challenging serve, but it'll be worth having in your bag of tricks. It's a mix of a power serve and a lob serve. You want to hit the ball deep into the court by brushing up on the ball to give it the topspin. It will feel like hitting a lob, but make sure to give it an upward trajectory. The topspin will make the ball go higher so that the receiver has to back up to return the serve, which is often a shot that many players aren't used to hitting. If done correctly, the receiver will not be able to return the serve, or it will be returned poorly, giving you the upper hand.

RESET SHOT

Not every shot needs to be hit high and with tons of power. Sometimes it's necessary to reset the level of play and get yourself out of the transition zone, hence the "reset" shot. This shot is intended for balls that come to you at knee height. In some cases (excluding the skilled rolls), hitting the ball higher will make it easier for your opponent to make a play. When you go for a reset shot, you get low enough that you can return their knee-level shot and keep the point of contact so low that they struggle to hit it back to you. As opposed to the rolls, in the case of a reset shot, you want to keep your wrist strong in place to hit the ball.



PLAY TO YOUR OPONENT'S WEAKNESS

We've talked a lot about how to improve your play. Now it's time to flip to the other side of the court. Where your opponent is.

As you get more confident in your ability to accurately place shots, the next step is to use that skill as a weapon.

You actually don't need many more shots in your toolbox. You can win matches by keeping the ball exactly where you want it. Which is at your opponent's foot.

Which foot?

That depends. Is your opponent right- or left-handed? And does your opponent have a stronger forehand or backhand?

Here's a chart of where you should aim to place the ball for different opponents.



Seem like a lot to keep straight in your mind? Welcome to junior year, picklers! We never said it would be easy. Wait, did we say it would be easy?

This is the kind of tactic that might go unnoticed by your opponent, which is the deadliest kind of skill. And this strategy takes patience. It's not a smash that's won in one stroke of greatness. It takes persistence to keep placing the ball where the opponent doesn't want it to be.

They may return several, but keep doing it, and they're bound to make a mistake.

PARTNER PLAY

You've likely dabbled in doubles since beginning your pickleball journey. We haven't talked much about it yet because everything we've learned thus far can absolutely be applied to playing with a partner.

But there are some additional tips that only apply to doubles.

Shall we?

The first is **Court Awareness**. When you're playing singles, you know exactly where you're going and when you're going. So being intentional about your Court Awareness isn't all that important.

Go along with us for a second. Imagine you're on stage, playing a guitar and singing a song. You're doing beautifully. Halfway through the song, you decide you want to change the ending. So you do. And no one's the wiser. Bravo, by the way.



Now, same scenario, but we're on stage with you. Happy to be here! We're playing piano right next to you as you sing and play. If you decide you want to change the song halfway through, we're going to need a head nod. At the least.

EXTRA CREDIT

Famous singer-songwriter, **Robbie Williams**,
plays pickleball.

Court Awareness works similarly. When playing with a pickleball partner, you want to let them know where you might go or where he/she should go. Verbally or otherwise.

For instance, if you're hitting a third shot drop, you'd want your partner to get up to the Kitchen Line to defend the return. But not too soon or you might hit them.

You may call out, "Drop!" before hitting it. Or once you've played with a partner long enough, you start to see the signs.

Next, let's talk **psychology**.

Whoa. Whoa. Whoa. We didn't sign up for psych! This is Pickleball University. Emphasis on the pickleball!

We hear you loud and clear. But getting the best out of your pickleball partner requires more than just pickleball skill. It requires, as the kids say, good vibes.

Our formula is easy. The three Cs.

COMMUNICATE

It's important to communicate before, during, and after the game. Before, you may want to offer your strengths and weaknesses, how you like to play, and anything you know about the opponents. During the game, communicate in real time and after points. As in, if you're taking a shot that comes right down the middle, a quick, "I go!" is a great way to avoid clashing. And after points, offer encouragement. No need for monologues. You're there to play. A simple "Nice!" is all they're looking for.

EXTRA CREDIT

We once played with a guy who said to us before the game, "Look, I'm just going to say 'sorry' now. I'm going to hit the ball in the net. I'm going to make mistakes. So I'm just going to get that out there now so we don't have to worry about it later." We have stolen this approach many times. Feel free to do the same.

COMPLIMENT

You're partners! And pickleball is fun. Woop it up out there. Fluff each other's feathers. It sounds elementary for a junior-level class. But we all need reminding. The mental side of the game is just as important as the physical side. So make sure you keep each other mentally healthy.

CLINK!

For what it's worth, this is our favorite C of the three. Clink! as in "cheers" your paddles after an exceptionally strong point. And Clink! as in head to happy hour together after the game.

Now, let's talk **Poaching**.

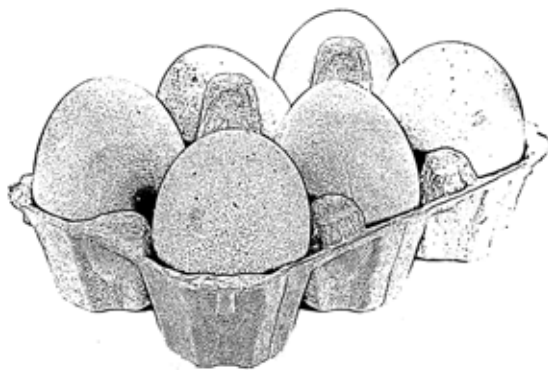

We'll save you the egg recipe and get right to what poaching means in pickleball.

Poaching can be defined as you moving across the Center Line into your partner's area of the court to hit a ball. This usually occurs when you are at the Kitchen Line, but it can also happen on the serve return or during a rally.

The point of it is to surprise your opponent. If they aren't expecting it, they might not be able to return it.

While poaching is a good strategy to mix things up in a game, you may not see it employed at lower levels or in recreational play. This is in part because you don't want to take your partner's ball, even if you are the better player. But poaching can be a very effective strategy, especially in situations where you are in front of your partner.

Here are some tips on to how to effectively poach.

Make sure to communicate with your partner ahead of time. This means you should both agree on the strategy before the game. Then take opportunities during play to execute it.

Poach when your partner is behind you and you have a forehand. If your partner is staying back in the court hitting ground strokes, then it really is advantageous to poach, as a doubles game is rarely ever won from the baseline.

Move right before your opponent hits the ball because you won't have time to poach if you move after your competition strikes the ball. Of course, your opponent may see this and try to hit behind you. But your movement may also distract them.

You are taking a risk by poaching, but the reward can be great. Fortune favors the bold!



Well, well, well. You've done it again. You've finished another year here at Pickleball University.

Though we could sit here and chat pickleball with you for decades, it's time to part ways again. But only briefly.

Take this junior-level knowledge and put it to good use on the court. Better yet, spread it with other pickleballers, too.

Class dismissed!



CHAPTER 4

SENIOR

Don't go catching senioritis on us! You've made it this far. It's time to finish up and finally get your degree in pickleball (certificates are a DIY situation, sorry about that).

You're here. A senior in pickleball. Your hopes are high.
We can tell.

You're probably thinking we're about ready to introduce you to a cartwheel serve. Or a behind-the-back-no-look-volley.

We are not.
(Call us if you do master either of those, though. Seriously.)

The truth is, pickleball is about mastering the basics, mixing in different shot types, and knowing how to play against different opponents. And then doing it so much that you play at your best every time you step on the court.

That's it. Class dismiss... Kidding. We've got much more ground to cover. It just might not be the ground you were expecting.

PICKLEBALL TOURNAMENTS



QUESTION:

Have you played in one yet?
If not, why?

- Fear of not knowing what to do.
- Fear of not being good enough.
- Fear of not knowing where to park.

We get it. Fear is the most popular answer to why people don't play in tournaments.

But playing in a tournament is one of the most effective ways to take your game from great to always great. Plus, they're fun.

Allow us to break it down into two parts.

1. PICKLEBALL

When you play in a tournament, especially one that is not in the town you usually play in, you compete against people you've never met. This pushes you out of your norm. On your home courts, you may know which shots to hit where depending on who you're playing. Now, in a tournament, you'll have to adapt quickly. Which helps build up some of your weaker spots.

It also allows you to learn from new opponents. Remember when you were just starting out? What was the best way to learn? (Aside from reading our freshman course, of course!) It's playing with a bunch of different people. You pick up different styles of play, different tips, different strategies from everyone. And it's no different your senior year. Other than you need to intentionally expose your pickleball play to a wider group of people. And tournaments are the perfect place to do so.

EXTRA CREDIT

USA Pickleball hosts at least 11 tournaments every year and supports and sanctions more than 200 tournaments annually throughout the United States.

You're also being watched by new people at tournaments. Not sure how to word that without it sounding creepy. But it's not! New people will see you playing, including your opponents. And you shouldn't be afraid to ask them after a match, "Hey, what do you think I could work on?" Pickleballers are the best and they'll absolutely be willing to help.

In some cases, you'll get to watch the pros. If you sign up for a large, sanctioned tournament, there will likely be a pro division. Which probably doesn't happen at your regular courts. So take full advantage of this. Watch these games and you'll learn a ton. See how the pros play singles and doubles, and we guarantee you'll pick up something new. A new shot placement. A new court position. A new serve. A new way to communicate with your partner. They are pros for a reason. Note those reasons.

Call us digital optimists (ehhmm, we run a website called PickleballUniversity.com, ehmm), but we love the way the internet connects the pickleball community. And it also gives us an infinite amount of pickleball highlight videos. Wait. Wait. Wait. Don't leave here and slide down the rabbit hole of searching pickleball on YouTube. Just know it's there. Especially after you attend a tournament. Check out highlights from that tournament when you get home to see exactly how the pros were playing. You'll find a whole new set of tips by reviewing game film this way.

2. PICKLEBALLERS

Where there's pickleball, there are pickleballers. And the pickleball community is a group we can't speak highly enough about. Sure, playing the game is fun. But if we're being completely honest, the community is what keeps people playing.

Before we go on.



You are in that community now. YOU. And you have the responsibility to keep that community positive, welcoming, competitive, and fun. You're a senior now. People look up to you, whether you know it or not.

Now, back to tournaments. When you're surrounded by so many other picklers, it's impossible to not have fun. Which is what this sport is all about. And you'll also meet pickleballers from around the country.

Big whoop.

Yeah, big whoop! Here's why this matters. When you sign up for a tournament, you may not have a doubles partner who is available or willing to play with you. Once you've attended a few tournaments and met some other great picklers, you can reach out to them and enter as doubles!

You'll also have delightful new friends you'll keep up with online, but we're not here to share tips on that. You're on your own there!

Okay, okay! I'm convinced. I'll play in (another) tournament.

Wonderful.

Here's what you need to know.

The internet is a wonderful place where you can search for pickleball tournaments near you. Likely, someone you already play with will have an idea of which one you should play in. But if not, start with an internet search.

From there, do your research. See how big the tournament is, where it's being played, and how much it costs to enter. All of it. Don't be afraid to call or email the tournament hosts. Remember: the pickleball community is full of wonderful people like just you. They will be happy to answer any questions you have.

When you find the perfect tournament, you will be asked some basic info, including what level of player you are. Or what your pickleball rating is.

EXTRA CREDIT

3.0 is the skill rating at which we recommend starting to play tournaments.

DEFINITION OF PLAYER SKILL RATINGS

1.0 - 2.0	You have a minimal understanding of the rules of the game. And minimal experience playing it.
2.5	You can rally with other beginners and know how to keep score.
3.0	You can hit forehands, backhands, and serves with confidence. But you're not great at placement yet. You can land a dink, but you probably can't sustain a dink rally.
3.5	You understand strategy and getting to the Kitchen Line quickly. You can sustain a medium-length dink rally. And you feel confident that you know where to hit the ball, even if you don't place it perfectly every time.
4.0	You're varying your serve depth and speed. You're placing Third Shot Drops regularly and even mixing up your Third Shots. You understand position on the court. And can hold a rally regularly.
4.5	You understand how to play to your opponent's weaknesses, and you vary your serves and Third Shots to force opponent's into tough returns. You never miss putaways, and you're confident dinking and volleying at the Kitchen Line.
5.0	You have mastered pickleball. From shot types and knowing when to use them to strategies and effective court movement, you're on top of your game. And you consistently play at your best.
5.0+	You're winning most tournaments you enter at the highest level of play.

WHY RATINGS MATTER

No one's trying to judge you or put you in a box. But ratings are extremely important when entering tournaments. You need to have an honest evaluation of yourself. So we'd even suggest grabbing someone you've played with and asking their opinion.

It's only intimidating once. Promise. The first time. Because you might not be totally sure. "Am I a 3.0 or a 3.5? A 4.0 or a 4.5?" It's okay. Make the decision and go play in a tournament! Because after you do, you'll have a much better sense of the nuances between ratings. And you'll be 100% confident in your rating after you play in a tournament.

BECOMING A PRO

The goal of a college education? To get a job, right?

We know. Pickleball is likely a competitive, fun way for you to stay active. And maybe you have zero desire to become a pro. We're in the same camp. That's why we became pickleball professors.

If you do want to become a pro, or simply are interested in what it takes, we're going to outline our three biggest pieces of advice.

And note: our advice is not about skill. That's obvious. You need to be really good at pickleball to become a pro. We're here to help you navigate logistics.

1. PICKLEBALL IS EVOLVING EVERY DAY

It's the wild west out there. USA Pickleball is the official governing body of pickleball in the United States. But there are also international associations and 2,000+ ambassadors within USA Pickleball. Meaning, there are tournament tours of all kinds and pros playing almost every weekend.

We say this to remind you that it's okay to ask for help on your pro journey. Between keeping up with current leagues and the introduction of new ones all the time, pickleball is evolving and you'll have to evolve with it, too.

2. ASK FOR HELP

Speaking of asking for help ... Ask for help. And we don't just mean the obvious. Friends and family. We mean brands, too. Becoming a pro is rather expensive. If you're playing 25 tournaments a year, you're looking at tens-of-thousands of dollars.

The good news? With such rapid growth in the sport, there are plenty of new and established pickleball brands on the scene. Don't be afraid to reach out to them to see if they'd be willing to sponsor you. Remember, you're on the road to becoming a pro. Act like one.

3. REACH OUT TO OTHER PROS

Since pickleball hasn't tipped to mainstream celebrity status quite yet, the pros are accessible and quite willing to help promote the growth of more pros. So don't be afraid to "ask dumb questions" to pros. We do it all the time for PickleballUniversity.com and we haven't met a single pro who wasn't willing to answer them.

**Dahhhhhh Dah Dee Dahhh Duhhhhhhhh
Duhhhhhhhhhh**

Hear that? That's the tune of graduation. So put on a goofy hat. Cut some arm holes out of a trash bag. And walk across your living room!

Congratulations! You have graduated from Pickleball University and we couldn't be prouder.

We're not going to drag this thing out to a 3-hour ceremony. You're welcome. But we will leave you with some parting words.

Pickleball has changed our lives. Which is both hilarious and serious. You have to laugh at the fact that something called "pickleball" has the power to change a life. And yet, you cannot deny that it's a fact.

We love the picklers we've met. And we love that we can stay active every day by playing with them. It sounds simple. Because it is. We've covered plenty in this book. But don't forget one thing.

That all of this comes down to staying active by playing a fun sport with really lovely people.

We'll see you out there.

CERTIFICATE OF ACHIEVEMENT

THIS CERTIFICATE IS
PRESENTED TO

(YOUR NAME HERE)

FOR OUTSTANDING
ACHIEVEMENT IN PICKLEBALL



PRESENTED BY

Dean Pickleball

OF PICKLEBALL UNIVERSITY



GLOSSARY

No need to put the following terms on index cards to memorize. We just wanted to leave you with a glossary of terms that we often hear on the court. Language is ever evolving and that's certainly true in pickleball, too. So if you don't find what you're looking for in our dictionary, there's never shame in asking a fellow pickler for guidance.

A

ACE

A serve that is not returned by the opponent. The point is won on the serve without being returned.

“ATP” AROUND THE POST

A legal shot whereby the ball is returned from outside the court and into the opposing team’s court, never passing over the net. May pass below the level of the top of the net.

B

BACKHAND

A shot made with your paddle arm across your body.

BACKHAND ROLL

A backhand, low-to-high stroke made on a ball that lifts the ball and applies a large amount of topspin while keeping the shot low.

BACKSPIN

Spin applied to the ball by hitting it while the paddle is moving from high to low,

causing the bottom of ball to rotate away from the hitter while in flight. A ball with backspin will have a tendency to slow or even stop forward motion once it contacts the ground.

BALL ON!

A shout indicating that an errant ball has entered the court, typically while some players are unaware.

BANGER

A player who typically hits every possible shot very hard, often from the baseline.

BASELINE

The line marking each end of the court.

BEER BRACKET

When you’re knocked out of the tournament early, you join the “beer bracket”.

C

CARRY

Paddle contact with the ball whereby the ball doesn’t immediately leave the face of the paddle during the hit, but

instead the ball and paddle remain in contact during a significant part of the stroke.

CENTER LINE

Extends from the Non-Volley Zone to the baseline and divides the service court into two equal halves.

CHAINSAW SERVE

A nickname for a serve popularized in 2021 by Zane Navratil, the serve involves pinching the ball between one hand and the paddle handle then tossing the ball in the air, imparting dramatic spin the process. Then as the ball drops, striking it with as much topspin as possible.

CHALLENGE COURT

During social play or a large group practice, a court where the winner(s) of a match stays and takes on the next challenger(s). Since there is no rule regarding this, variations abound, such as limiting a winning player to a set number of games on the challenge court.

CONTINENTAL GRIP

Holding the paddle in your hand as you'd hold a hammer, the most common grip. This grip can be used for forehands and backhands.

CROSSCOURT SHOT

To hit the ball to the opponent's portion of the court diagonally opposite from your own.

D

DEAD BALL

A ball is declared after a fault, the point is over.

DILLBALL

Shot that is in bounds and has bounced once. A live ball.

DINK

A soft shot that goes over the net and lands in the opposing Non-Volley Zone ("the Kitchen").

DOUBLE BOUNCE RULE

After each serve, the ball must bounce once on each side of the net before it can legally be volleyed.

E

ERNE

A volley from immediately left or right of the Non-Volley zone (outside of the court).

F

FALLAFEL

A shot that doesn't reach its full potential, due to the player hitting the ball without any power.

FLABJACK

A shot that must bounce once before it can be hit.

FOOT FAULT

When a player's foot illegally touches the Non-Volley Zone while volleying or when both feet are not fully behind the server's service court during the serve.

FOREHAND

Hitting the ball on the same side of the body as the hand holding the paddle.

G

GOLDEN PICKLE

Winning a game using solely the very first server, with the opposing team never serving.

H

HALF VOLLEY

Hitting a ball almost instantaneously after it bounces and well before it reaches its full bounce height. Sometimes called a short hop.

I

INDOOR PICKLEBALL

Softer and lighter plastic with larger holes to provide more accurate shots and a better bounce on indoor surfaces.

K

KITCHEN

Technically called the No-Volley Zone, or Non-Volley Zone, the Kitchen is

a 7-foot area on both sides of the net that the players cannot make contact with unless the ball bounces.

KITCHEN LINE

The line that extends seven feet from both sides of the net and from sideline to sideline that the players cannot contact unless the ball bounces.

L

LOB

A shot high over an opponent's head, forcing him or her back from the net.

M

MXD

An abbreviation sometimes seen for mixed doubles.

N

NASTY NELSON

Serving into the body (or paddle) of the partner of the receiver which results in

a point for the server due to interference rules.

NICE GET!

Affirmation to your partner or opponent after returning a tough shot.

NO-VOLLEY ZONE

Also known as the Kitchen, the No-Volley Zone is the 7-foot area on both sides of the net that the players cannot make contact with unless the ball bounces.

O

OPA!

Continuous play that occurs after the serve and before a fault.

OUTDOOR PICKLEBALL

Heavier with harder plastic and smaller holes. These features allow for increased durability, wind resistance, and bounce.

P

PADDLE

The thing you're hitting a pickleball with. Don't call it a racquet. The right term is pickleball paddle.

PICKLEBACK

The matches that occur in the loser's/consolation bracket of a standard double elimination tournament. (Or a shot of your favorite spirit followed by a shot of pickle juice.)

PICKLEBALL

A paddleball sport that combines elements of badminton, table tennis, and tennis. Played indoors or outdoors on a level court with short-handled paddles and a perforated plastic ball volleyed over a low net by two players or pairs of players.

PICKLEBALLER

A person who plays pickleball or is involved in the pickleball community.

PICKLED

When a team scores zero points in a whole game.

PICKLEDOME

The court where the championship match in a pickleball tournament is played.

PICKLER

The shorter, "cooler" version of pickleballer.

POACH

Poaching is where one team member will take the shots going toward their partner, instead of letting the partner play.

R

RALLY

Continuous play that occurs after the serve and before a fault.

RESET SHOT

Wherever you are in the court, you hit a soft shot that drops into the Kitchen in much the same way as you would try to hit a 3rd shot. You are going for the same effect, which is to hit an unattackable ball and follow it into the net.

S

SERVICE LINE

A line on a court marking the boundary of the area in which the server must be standing when serving.

SMASH

The most aggressive offensive shot in pickleball. The smash is a forceful hit executed as high in the air as the player can reach and directed downward at a sharp angle into your opponent's court. A well-executed smash is almost impossible to defend.

T

THIRD SHOT DRIVE

A driving shot that gives the opponent a much harder hit 4th shot that does not drop in the Kitchen. The goal is to then receive a more favorable 5th ball that allows you to approach the Kitchen safely.

THIRD SHOT DROP

A shot or long dink performed at or near the baseline that lands softly

in the opponent's Kitchen (Non-Volley Zone). This shot is designed with mostly one thing in mind, to allow your partner/team to get to (or at least move toward) the net.

TOPSPIN

A ball that rotates forward as it is moving. Topspin on a ball propelled through the air imparts a downward force that causes the ball to drop.

V

VOLLEY

This shot picks the ball out of the air before it bounces. This move is not allowed when the player is in the Kitchen or before the first 3 rallies.



For more pickleball tips and regular updates on all things
pickleball, join us at PickleballUniversity.com.

PICKLEBALL UNIVERSITY

Pickleball University is the best (and quite possibly the only?) school for pickleball. Our curriculum covers everything from freshman-level basics to senior-level strategies. So whether you're just starting out, looking for a professor to guide you through your pickleball journey, or you're a "transfer student" who wants to pick up upper-classman learnings, Pickleball University is the place for you.

"It's like actual college. Without the terrible cafeteria food."

-Jamie, Junior

"I must say, I never thought pickleball would be my cup of tea, but after seeing what Pickleball University has to offer, I now play every day."

-Dr. Tennis, Professor at Tennisball University

"I thought this was about making your own pickles. So I signed up. Turns out, it was something better! Pickleball! I love the sport so much now, I can't leave PBU."

-Tommy, 6th Year Senior

PICKLEBALLUNIVERSITY.COM